

design 22.5 x 75 x 110mm

multi-function

turn-on delay
 turn-on delay, instant
 turn-on timed
 turn-off delay
 clocked, starting with pulse
 clocked, starting with pause
 pulse forming
 star/delta switchover



- ✓ functions and time ranges adjustable via DIP-switch
- ✓ large time ranges with high repeat accuracy
- ✓ 2 integrated relays / change-over contacts
- ✓ remote control via remote potentiometer
- ✓ wide range power supply
- ✓ DIN-housing for mounting on DIN-rail
- ✓ LED function display

**multi-function time delay relay
 8 functions and time ranges**

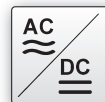

description

The DIP switches on the front of the unit are used to set the times, functions and output relays. Eight functions are available, see function diagrams. The potentiometer on the front plate is used for the fine adjustment of the time settings. The time may be set in eight ranges from 0.1 second to 300 minutes. Green and red LEDs serve to display the operating mode. The green LED signals the operational readiness. The red LED shows the energizing of relay 1. In the star/delta function the red LED will also light up when relay 2 energizes.

As soon as the operating voltage has been applied the internal processor loads the function and the fundamental time range that has been set on the DIP-switches. New settings on the DIP switches will not become effective until after the operating voltage has been interrupted and then reapplied. Time-settings that have been altered through the potentiometer are acquired during the operation.

The housing is mounted on a 35mm DIN-rail. The operating voltage should be applied to terminals A1 and A2. The make contacts (terminals) of the two integrated relays can be wired as you like. They operate differently depending on the

selected function. The floating encoder contact that is required for some functions is connected to the B1 and B2 terminals. If no floating contact is available an external control voltage must be connected to terminal B2 corresponding to the potential on A1.

The remote potentiometer is connected to the terminals Z1 and Z2. Any remote potentiometer that is connected is recognized automatically by the device after the operating voltage has been applied.

The maximum resistance of the encapsulated potentiometer is 10kΩ. The feed line must be shielded and earthed and must not be longer than one meter.

important notes

- ▶ automatic run-up controls for motors
- ▶ lighting controls
- ▶ fan controls
- ▶ traffic light controls
- ▶ elevator and escalator controls
- ▶ time-controlled processes
- ▶ precisely-timed operation

article-no.	ZM565453
version	multi-function time delay relay

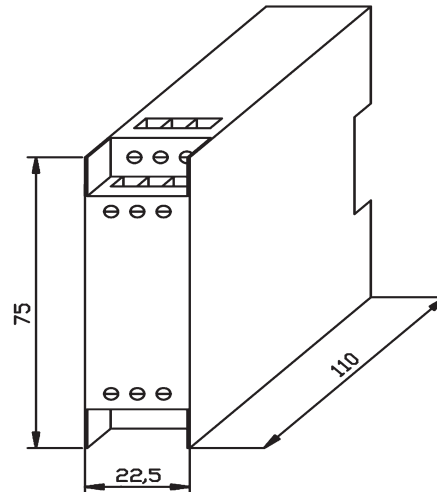

TECHNICAL DATA

adjustment (time)	0.1sec ... 300min / analog / 8 time ranges
operating voltage	24V AC/DC ... 240V AC/DC +5% ... -10%
input B2 (signal level)	10V AC/DC ... 300W AC/DC
power consumption	1 ... 5VA
continuous duty	100% CD
output signal	relay output, 2 change-over contacts
contact rating	inrush current 7A, constant current 3A, cut-off current 2A
contact life	at 0.5A approx. 2.5x10 ⁷ operating cycles
relay decay time	approx. 20msec
repeat accuracy	approx. ±10msec
temperature dependency	< 0.1%/Kelvin
power-on delay time	approx. 110msec
system of protection (EN 60529)	housing IP40, terminals IP20
operating temperature	-20°C ... +60°C, no condensation allowed
housing material	12-pin insulation material housing, polycarbonate
connection	touch guarded according to VDE 0100 and VBG 4, max 4mm ²
mounting	35mm DIN-rail (old: DIN EN 50022 / new: DIN EN 60715 TH35)

time function:	turn-on delay	turn-on instant (relay 2)	turn-on timed	turn-off delay	clocked, start with pulse	clocked, start with pause	pulse forming	star/delta switchover
S1	OFF	ON	ON	OFF	OFF	ON	OFF	ON
S2	OFF	OFF	ON	ON	OFF	OFF	ON	ON
S3	OFF	OFF	OFF	OFF	ON	ON	ON	ON

time range:	0.1sec ... 1sec	0.5sec ... 10sec	5sec ... 60sec	30sec ... 120sec	1min ... 5min	3min ... 10min	5min ... 60min	30min ... 300min
S4	OFF	ON	OFF	ON	OFF	ON	OFF	ON
S5	OFF	OFF	ON	ON	OFF	OFF	ON	ON
S6	OFF	OFF	OFF	OFF	ON	ON	ON	ON

turn-on delay

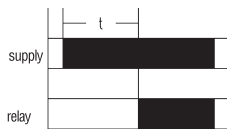

turn-on delay with instant contact

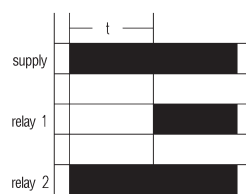

timed turn-on contact

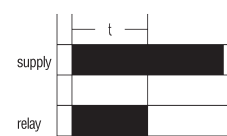

turn-off delay

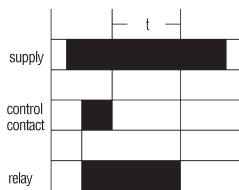

clocked, start with pulse

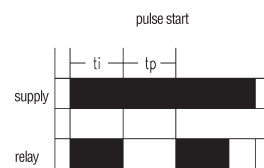

clocked, start with pause

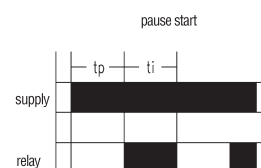

pulse forming

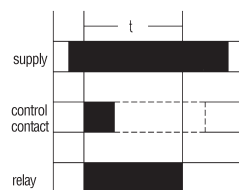

star / delta switchover

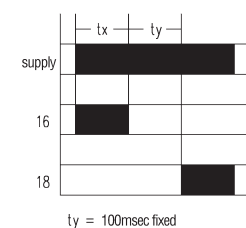

notes

For direct current operation connect the positive pole to terminal A1.

Terminal B1 has always the same potential as terminal A1 (possibly supply voltage).

Do observe the technical data on the reverse.

A remote potentiometer with metal axis must be earthed.

The device may only be operated with the plexiglass cover in place.

After the device has been successfully installed, no manipulation with tools should be carried out whilst it is operating.

connection

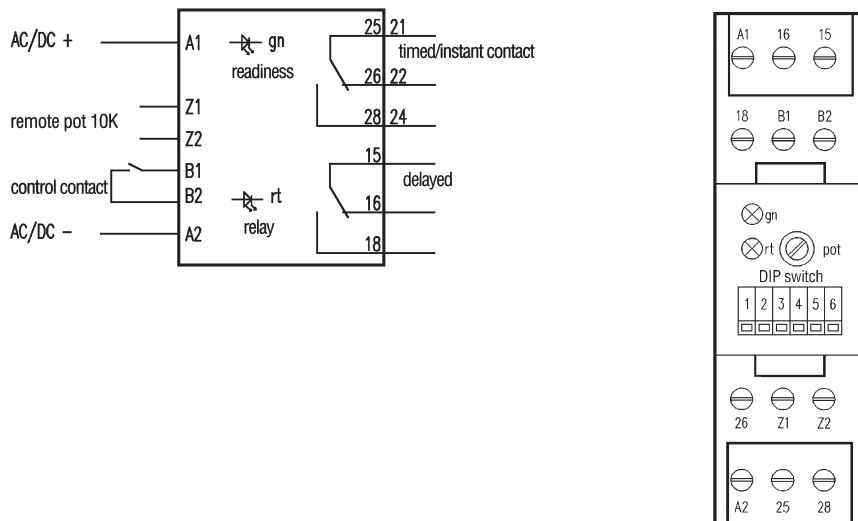

accessories

fig. 2

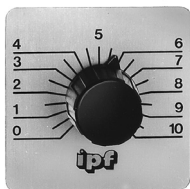

fig. 3



fig. 4



article-no.	description	note	fig.
AZ000004	time delay relay, remote potentiometer 10kOhm, Ø10	soldered connection	2
AZ000005	time delay relay, remote potentiometer 10kOhm, Ø22.5	soldered connection	3
AZ000006	time delay relay, remote potentiometer 10kOhm, Ø22.5	screw connection	4

Warning: Never use these devices in applications where the safety of a person depends on their functionality.